

| PART NO.   | DIMENSIONS         |               |               |               |               |               | WEIGHT    |     |
|------------|--------------------|---------------|---------------|---------------|---------------|---------------|-----------|-----|
|            | "A" NOM.<br>IN. MM | "B"<br>IN. MM | "C"<br>IN. MM | "D"<br>IN. MM | "E"<br>IN. MM | "F"<br>IN. MM | LBS       | KGS |
| 1.31LSTN   | 1 / 25             | 19.00 / 483   | 8.00 / 203    | 5.56 / 141    | 6.75 / 171    | 0.81 / 21     | 62 / 28.1 |     |
| 1.2531LSTN | 1.25 / 30          | 19.00 / 483   | 8.00 / 203    | 5.56 / 141    | 6.75 / 171    | 0.81 / 21     | 62 / 28.1 |     |
| 1.531LSTN  | 1.5 / 40           | 19.00 / 483   | 8.00 / 203    | 5.56 / 141    | 6.75 / 171    | 0.81 / 21     | 61 / 27.7 |     |
| 2.31LSTN   | 2 / 50             | 18.00 / 457   | 8.00 / 203    | 5.56 / 141    | 6.75 / 171    | 0.81 / 21     | 60 / 27.2 |     |
| 2.531LSTN  | 2.5 / 65           | 22.75 / 578   | 9.00 / 229    | 7.63 / 194    | 6.75 / 171    | 0.81 / 21     | 92 / 41.7 |     |
| 3.31LSTN   | 3 / 75             | 21.00 / 533   | 9.00 / 229    | 7.63 / 194    | 6.75 / 171    | 0.81 / 21     | 90 / 40.8 |     |

NOTES:

- ALL DIMENSIONS ARE IN INCHES [MM].
- DESIGN DATA:  
 DESIGN PRESSURE- 250 PSIG [17.2 BARS]  
 DESIGN TEMPERATURE- 450° F [232.2 °C]  
 MIN. DESIGN METAL TEMP.- -20° F @ 250 PSIG  
 [-28.9° C @ 17.2 BARS]
- MATERIAL: BODY & COVER - CAST IRON, SA-278 CLASS 30  
 INTERNALS - STAINLESS STEEL  
 GASKET - NON-ASBESTOS
- REDUCER BUSHING USED ON 2-1/2", 1-1/2", 1-1/4" & 1" CONNECTION.

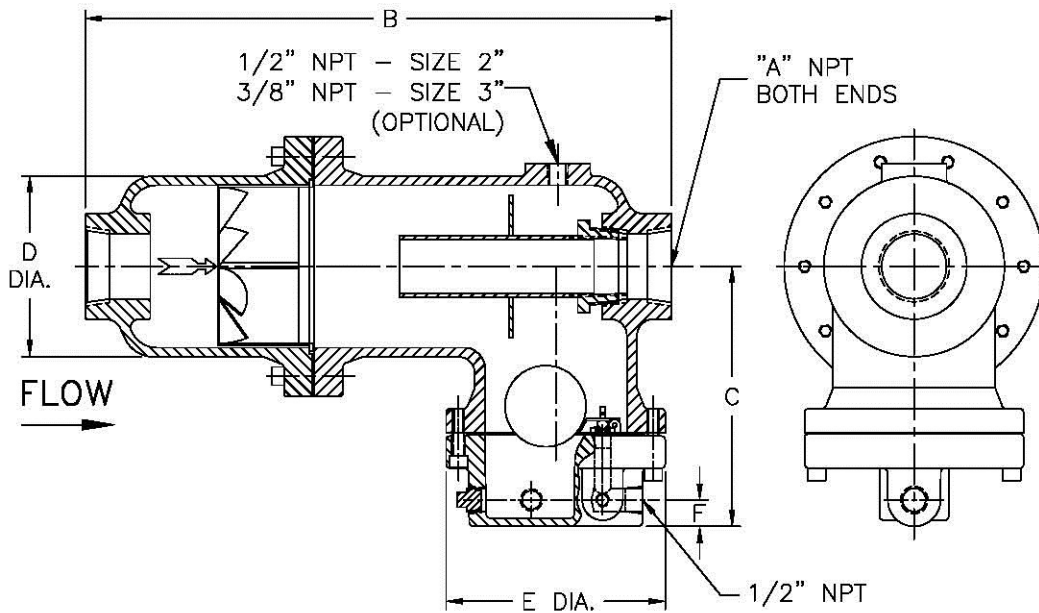

CERTIFIED FOR:

P.O. NO.:

S.O. NO.:

QUOTE NO.:

TAG NO.:

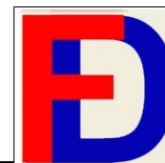

FACTORY DIRECT PIPELINE PRODUCTS, INC.  
<http://www.fdpp.com>

NAME TYPE 31L-ST GAS / LIQUID  
 SEPARATOR - TRAP  
 SIZES 1" - 3" NPT CAST IRON

DRAWN FM DATE 6/24/04 CERT. VAA DATE 6/25/04

SIZE DWG NO. REV  
 A SD31LSTN E

ELECTRONIC FILE NAME: SD31LSTN.DWG  
 REF. ECR D507 DATE 10/18/05

UNAUTHORIZED USE, MANUFACTURE OR REPRODUCTION IN WHOLE OR IN PART IS PROHIBITED. DRAWING, DESIGN AND OTHER DISCLOSURES PROPERTY OF EATON FILTRATION, LLC