

PIPE SIZE (NOMINAL) IN. MM	DIMENSIONS							DRY WEIGHT		PART NO.		
	"A"		"B"		"C"		"D"	"E"	"F"		LBS	KGS
	IN.	MM	IN.	MM	IN.	MM	CONNECTION	VENT	DRAIN			
3/4 (20)	5.50	140	9.19	233	5.75	146	3/4" NPT	1/4" NPT	3/4" NPT	22	10	0.75TAN
1 (25)	6	152	9	229	6.75	171	1" NPT	1/4" NPT	1" NPT	25	11.4	1.TAN
1-1/4 (32)	6	152	9.13	232	7	178	1-1/4" NPT	1/4" NPT	1" NPT	28	12.7	1.25TAN
1-1/2 (40)	7.25	184	11.69	297	8.13	207	1-1/2" NPT	1/4" NPT	1" NPT	44	20	1.5TAN
2 (50)	8.13	206	13.69	348	8.50	216	2" NPT	1/4" NPT	1" NPT	47	21.3	2.TAN
2-1/2 (65)	9.38	238	14.38	365	10.00	254	2-1/2" NPT	1/4" NPT	1" NPT	89	40.4	2.5TAN
3 (80)	11	280	15.94	405	11.38	289	3" NPT	1/4" NPT	1-1/4" NPT	107	48.5	3.TAN

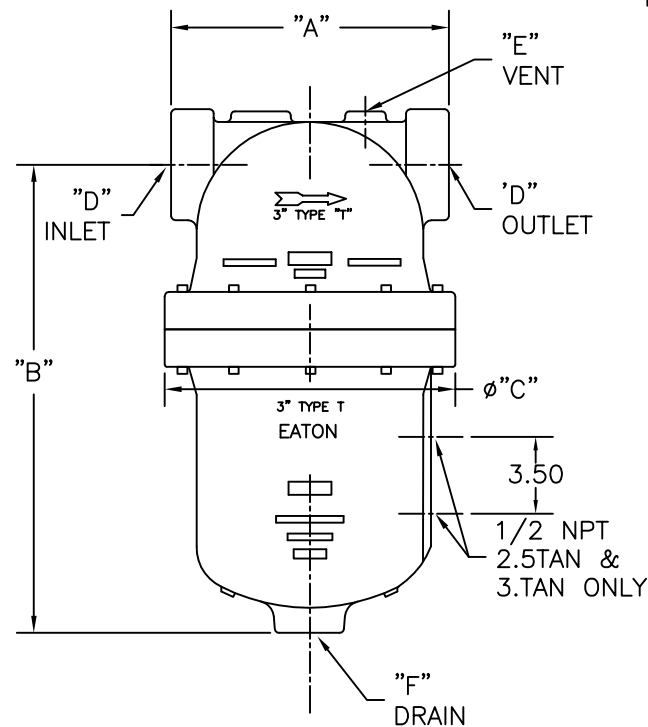

NOTES:

1. UNITS ARE TO BE DESIGNED, FABRICATED IN ACCORDANCE WITH ASME B & PV CODE, SECTION VIII, DIVISION 1 IN COMPLIANCE TO CURRENT PUBLISHED ADDENDA.

2. ALL DIMENSIONS ARE IN INCHES [MM].

3. DESIGN DATA:

DESIGN PRESSURE-	250 PSIG [17.2 BARS]
DESIGN TEMPERATURE-	450° F [232.2 °C]
MIN. DESIGN METAL TEMP.-	-20° F @ 250 PSIG [-28.9° C @ 17.2 BARS]
HYDROTEST PRESSURE-	500 PSIG [34.5 BARS]
CORROSION ALLOWANCE-	0 INCHES

4. MATERIAL: CAST IRON, SA-278 CLASS 30

QUICK & DISCOUNTED PRICING
CLICK HERE
 OR CALL (908) 362-9981

EATON		EATON FILTRATION, LLC 70 WOOD AVENUE SOUTH, ISELIN, NEW JERSEY 08830					
		NAME TYPE "T" GAS LIQUID SEPARATOR THREADED LINE CONNECTIONS CAST IRON					
DRAWN	VA	DATE	11/25/03	CERT.	FM	DATE	11/25/03
SIZE	DWG	SD-TAN				REV	H
A	NO						

ELECTRONIC FILE NAME: SD-TAN.DWG
 REF. ECR 0065233 DATE 12/20/11

UNAUTHORIZED USE, MANUFACTURE OR REPRODUCTION IN WHOLE OR IN PART IS PROHIBITED. DRAWING, DESIGN AND OTHER DISCLOSURES PROPERTY OF EATON FILTRATION, LLC